

Loads and fixings (up to 5m travel)

Table				
Position	X (KN)	Y (KN)	Z (KN)	Comments
A	0	±1.2	0	Door threshold fixing at each entrance
B	+2.5	±0.9	0	Guide side top fixing
C1	±3.3	0	0	Guide side landing fixing
C2	±3.4	±1.2	0	Guide side intermediate landing fixing, travel between floors >3.0m
D	-1.6	±1.1	+2.6	Floor loads, laminate infill panels
D	-1.6	±1.1	+3.7	Floor loads, glass infill panels
E	0	0	+0.7	Vertical load at the base of each car guide
F	0	0	+18.2	Vertical load at the base of hydraulic ram
G	0	0	+17.0	Vertical load at the lift car buffer

Notes:

- Details provided apply to Midlift SLplus indoor applications, max 5m travel, where all specified fixings can be made directly into solid substrate or structural members. The table & sketches show all loads applied by the lift, through fixings (where applicable) to the building structure.
- Loads
Loads from the lift occur in all 3 axes (X, Y & Z). All values stated in the table are per position indicated in the sketches. All loads stated are for 'worst case' conditions (of load & travel). Where applicable, appropriate impact factors have been accounted for.
 - Horizontal plane fixings
Fixings at lettered positions (A, B, C1 & where applicable, C2) are compulsory. Forces apply in directions indicated in the table. Positive directions are shown in the sketch 'Positive axes'. Fixings C2 are only required when the distance between floors is greater than 3.0m. Pitch between C fixings to be maximum 3.0m, minimum 1.5m.
 - Vertical plane fixings
Fixings at D are compulsory. Fixings at D are made (vertically) into floor & are subject to loads in the X, Y & Z axes, as shown in the table. Loads in the Z axis at D are point loads due to structure weight.
- Preferably, the lift well should not be situated above a space accessible to persons. If spaces accessible to persons exist below the lift well, then base of the pit shall be designed for an imposed load of 5kN/m².
- It shall be the customer's responsibility to ensure suitability of the building structure for the applied loads, both in terms of strength, & also suitability of the fixings proposed. If any doubts exist, it is advised that a structural engineer is consulted.
- All dimensions in mm unless otherwise stated.
- Provisions for securing the lift must be flush with the lift aperture and of sufficient thickness/depth to accommodate the appropriate fixing. Exact positions and types of fixings will be detailed on a site specific builders work drawing.

FIXING TYPES USED		
FIXING POSITION	MATERIAL	COMMENTS
A, B, C	Concrete	M12 studding ste into hilti HY70 resin with minimum embedment of 90mm.
A, B, C	Timber	10mm coach screws into timber beam with minimum depth 70mm.
A, B, C	Steel	M12 studding drilled and tapped into a steel plate of thickness 8mm.
D	Concrete	10mm expandable anchor with minimum depth 120mm.

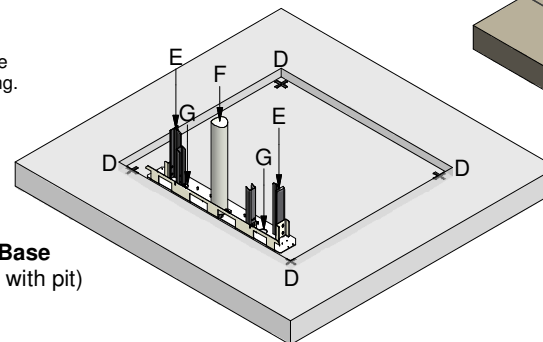

Lift Base
(Shown with pit)

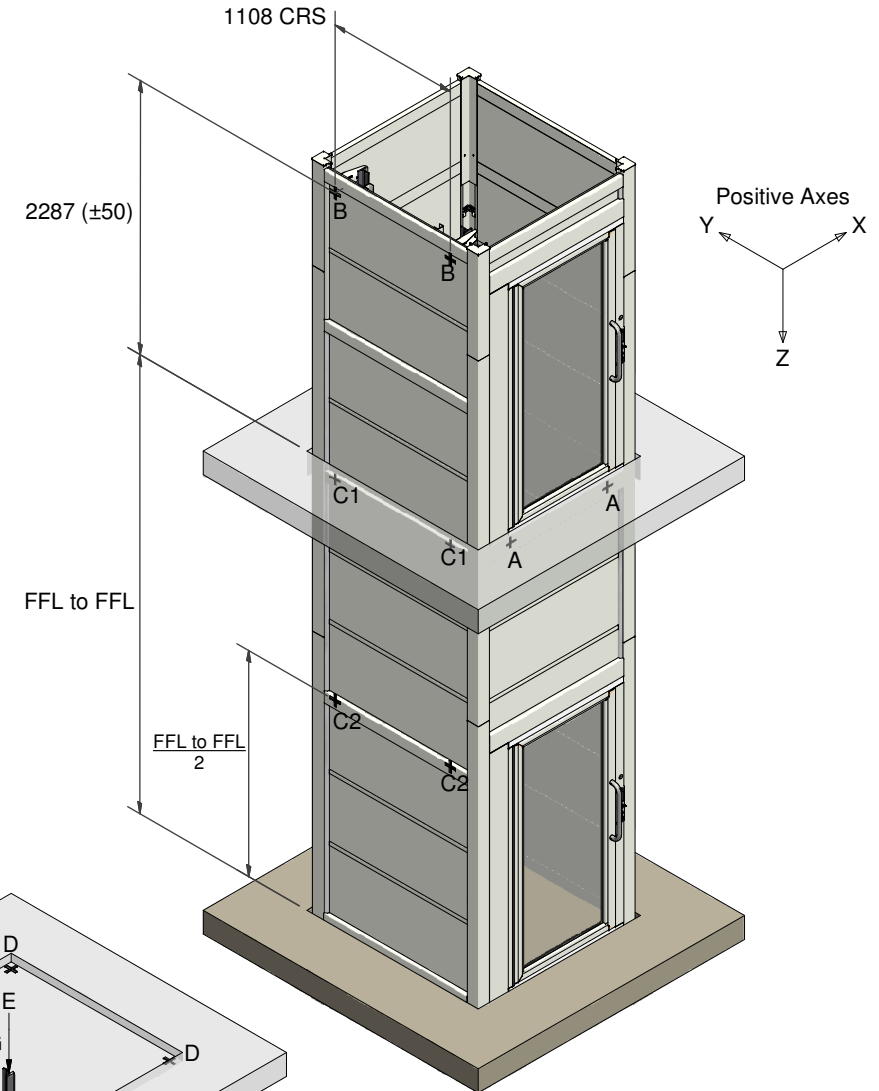

Lift Structure
(Up to 5m Travel)

Waiver

The data sheet is for guidance only & must not be used for proper working drawings. Please contact us for particular details before proceeding. Owing to our policy of continual improvement, we reserve the right to alter specifications & dimensions without prior notice.